

1.25mm Terminal / Housing / Wafer SMT Straight Type

Specifications
 Current Rating: 1A AC,DC
 Voltage Rating: 150V AC,DC
 Temperature Range: -25°C to +85°C
 Contact Resistance: 30mΩ Max
 Insulation Resistance: 500MΩ Min
 Withstanding Voltage: 500V AC/minute
 Terminal: Brass / Gold Plated
 Solder Tabs: Brass / Gold Plated
 Material:Housing: Nylon 66, UL94V-0
 Wafer: Nylon 6T, UL94V-0

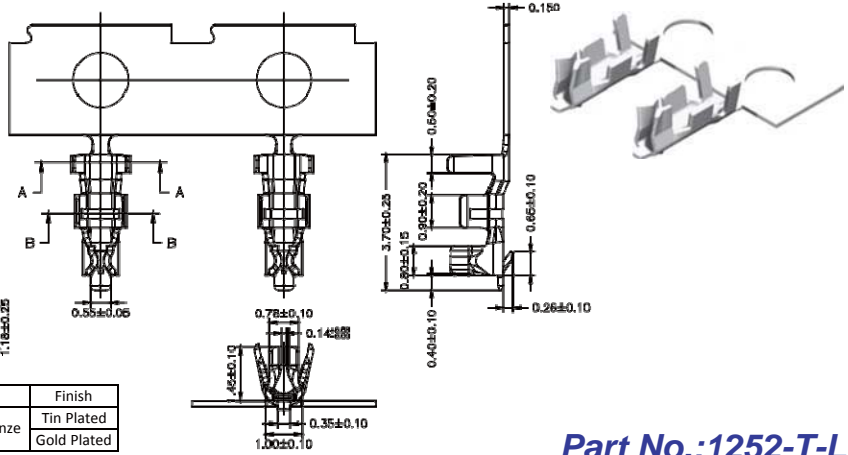
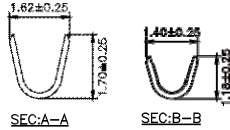

Part No.	Wire Range	Insulation O.D.	Material	Finish
1252-TTP-L	#26-#30	1.00mm(Max)	Phosphor Bronze	Tin Plated
1252-TGP-L				Gold Plated

Part No.:1252-T-L

Housing Wafer Terminal

No. of Contacts	Dimensions	
	A	B
2x5	5.00	10.40
2x7	7.50	12.90
2x10	11.25	16.65
2x15	17.50	22.90
2x20	23.75	29.15

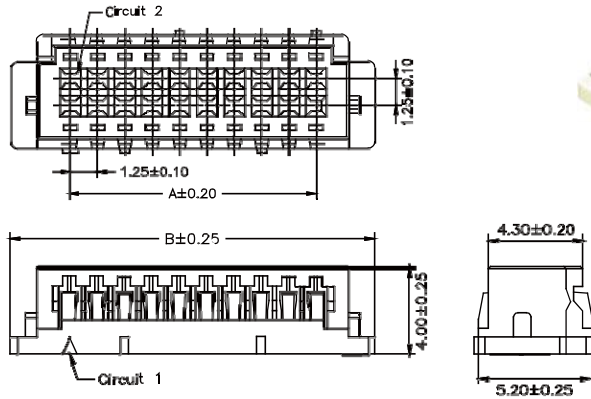

Part No.:1252H-2XXW-L

No. of Contacts	Dimensions		No. of Contacts	Dimensions	
	A	B		A	B
2	1.25	4.15	9	10.00	12.90
3	2.50	5.40	10	11.25	14.15
4	3.75	6.65	11	12.50	15.40
5	5.00	7.90	12	13.75	16.65
6	6.25	9.15	13	15.00	17.90
7	7.50	10.40	14	16.25	19.15
8	8.75	11.65	15	17.50	20.40

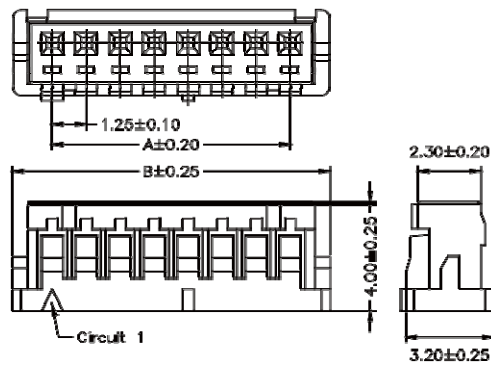

Part No.:1252H-1XXW-L

No. of Contacts	Dimensions	
	A	B
2x5	5.00	12.50
2x7	7.50	15.00
2x10	11.25	18.75
2x15	17.50	25.00
2x20	23.75	31.25

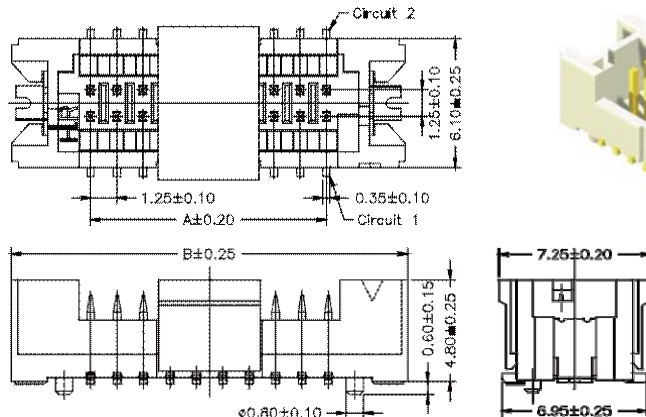
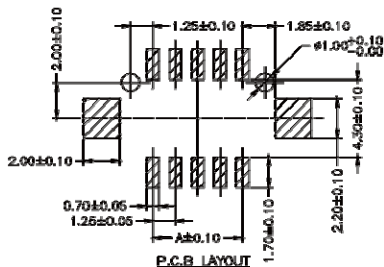

Part No.:1252MS-2XXGW-U