

## 2.5mm Terminal / Housing / Wafer Right Angle & Straight Type

**Specifications**

Current Rating: 3A AC,DC  
Voltage Rating: 250V AC,DC  
Temperature Range: -25°C to +85°C  
Contact Resistance: 30mΩ Max  
Insulation Resistance: 500MΩ Min  
Withstanding Voltage: 1500V AC/minute  
Terminal: Brass / Tin Plated  
Material: Nylon 66, UL94V-0

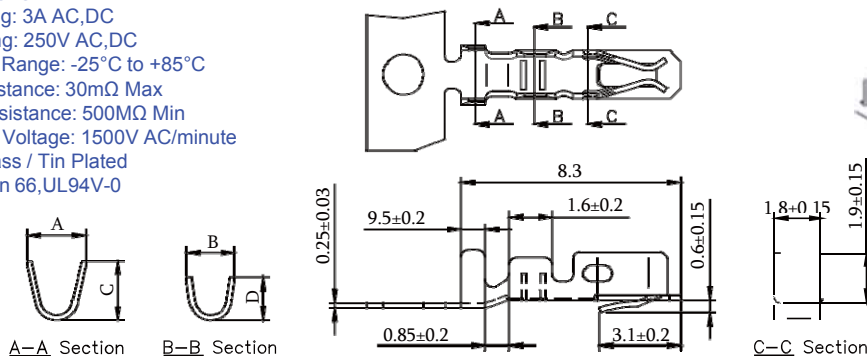

Part No.	Wire Range	Insulation O.D.	Material	Finish	A	B	C	D
2517-T-L	#22-#26	1.7~1.35mm(Max)	Phosphor Bronze	Gold Plated	2.30	1.90	2.25	1.65
2517-T-A-L	#28-#30	1.2~1.05mm(Max)			2.05	1.40	2.05	1.30

**Part No.:2517-T-L**

No. of Contacts	Dimensions	
	A	B
2	2.50	7.10
3	5.00	9.60
4	7.50	12.10
5	10.00	14.60
6	12.50	17.10
7	15.00	19.60
8	17.50	22.10
9	20.00	24.60
10	22.50	27.10
11	25.00	29.60
12	27.50	32.10
13	30.00	34.60
14	32.50	37.10
15	35.00	39.60

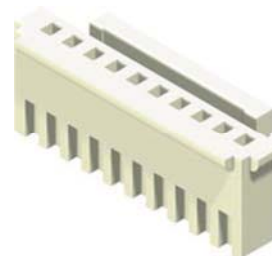
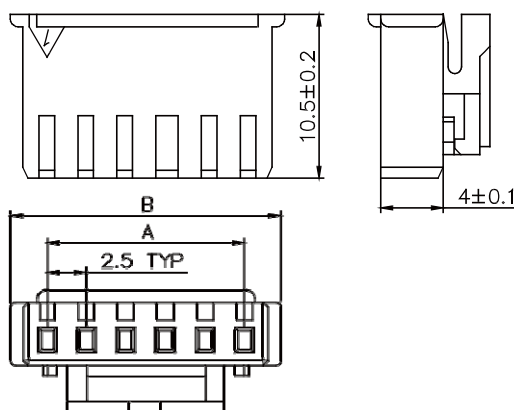

**Part No.:2517H-XXW-L**

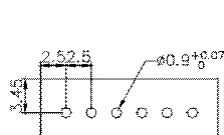

Applicable P.C.B Thickness: 1.6mm

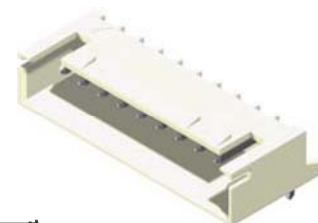
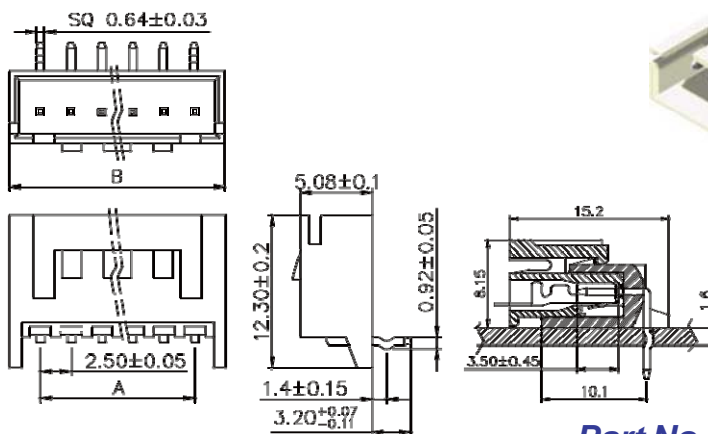

**Part No.:2517R-XXTW-L**

No. of Contacts	Dimensions	
	A	B
2	2.50	7.50
3	5.00	10.00
4	7.50	12.50
5	10.00	15.00
6	12.50	17.50
7	15.00	20.00
8	17.50	22.50
9	20.00	25.00
10	22.50	27.50
11	25.00	30.00
12	27.50	32.50
13	30.00	35.00
14	32.50	37.50
15	35.00	40.00

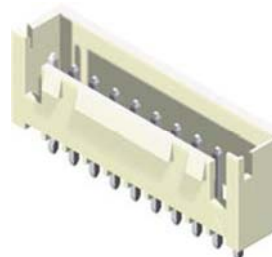
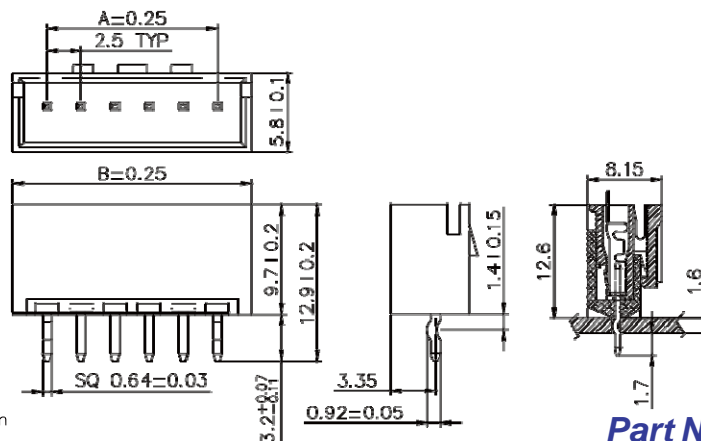

**Part No.:2517S-XXTW-L**

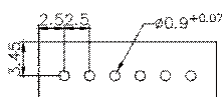

Applicable P.C.B Thickness: 1.6mm