

CONNECTORS MANUFACTURER

DIN 41612 Long Body B Type Male

SPECIFICATION

Current Rate: 2 AMP
 Insulation Resistance: 1000MΩ Min.
 Contact Resistance: 30mΩ Max.
 Dielectric Voltage: 1000V AC for one minute
 Operation Temperature: -55°C to +105°C

MATERIAL

Insulator: Polyester, UL 94V-0
 ©Standard: PBT
 Contact Pin: Brass

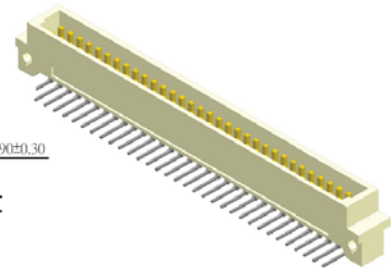
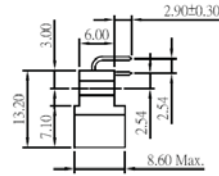
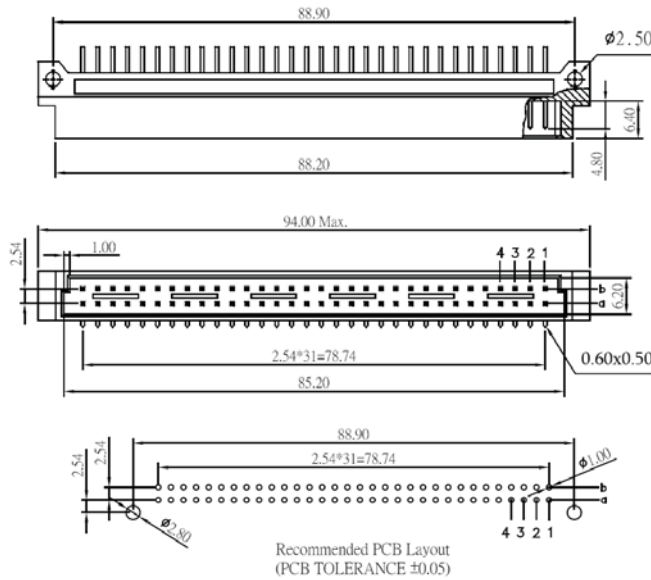

No. of Contacts	Rows/Positions With Contacts	Pitch
64	a+b	2.54mm
32	a	
32	a+b All Even No.	5.08mm Half-Loaded
16	a All Even No.	

Part No.: DINLR-M2XX-L

DIN 41612 Long Body B Type Female

SPECIFICATION

Current Rate: 2 AMP
 Insulation Resistance: 1000MΩ Min.
 Contact Resistance: 30mΩ Max.
 Dielectric Voltage: 1000V AC for one minute
 Operation Temperature: -55°C to +105°C

MATERIAL

Insulator: Polyester, UL 94V-0
 ©Standard: PBT
 Contact Pin: Phosphor Bronze

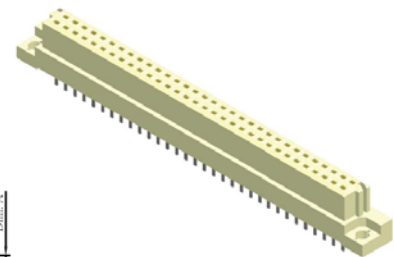
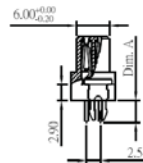
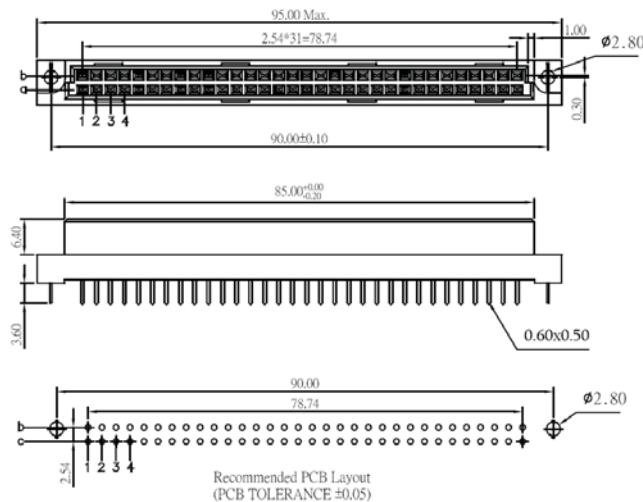

No. of Contacts	Rows/Positions With Contacts	Pitch
64	a+b	2.54mm
32	a	
32	a+b All Even No.	5.08mm Half-Loaded
16	a All Even No.	

Part No.: DINLS-F2XX-L

ORDER INFORMATION

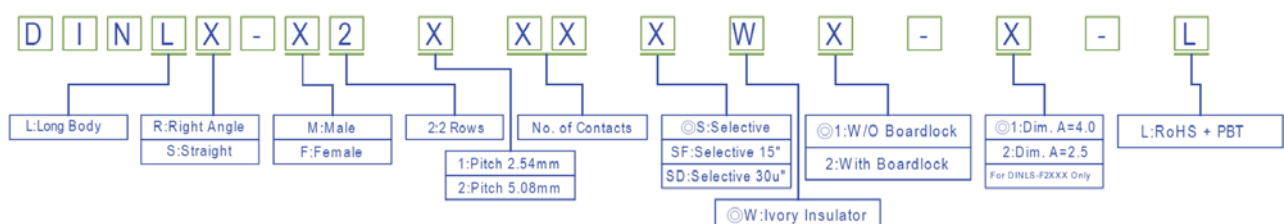

©: Standard Recommended

DIN 41612 Conn. Series

RoHS