

REV.	DESCRIPTION	DRAWN	CHECKED	APPROVED
A	NEW RELEASE	TYF 06/03/04'	谭玉芬	

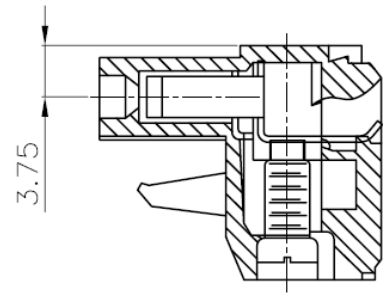
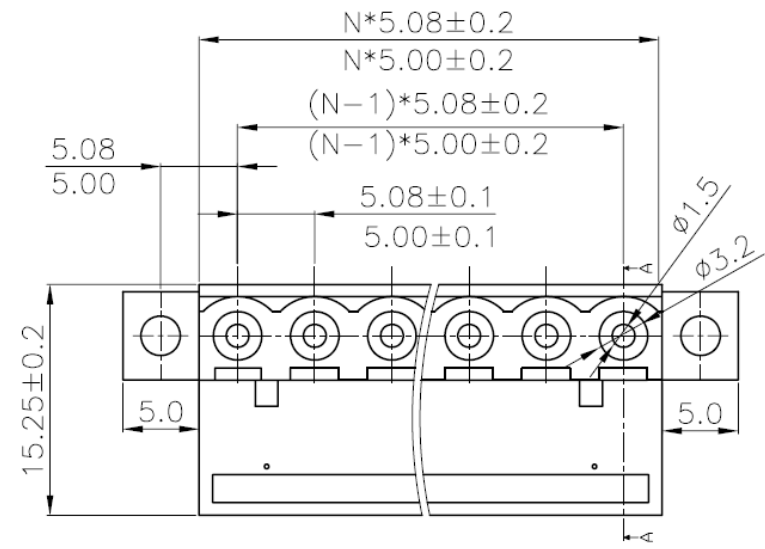

SECTION A-A

- MATERIAL  
CONTACT : PHOSPHOR BRONZE  
SCREWS : M2.5 STEEL ZINC PLATED  
HOUSING : PA66, UL94V-0
- ELECTRICAL  
RATED VOLTAGE : 300V  
RATED CURRENT : 15A  
CONTACT RESISTANCE : 20mΩ  
INSULATION RESISTANCE : 5000MΩ/1000V  
WITHSTANDING VOLTAGE : AC2000V/1Min  
WIRE RANGE : 28-12AWG 2.5mm<sup>2</sup>
- MECHANICAL  
TEMP.RANGE : -40°C~+105°C  
MAX SOLDERING : +250°C, FOR 5 SEC.  
TORQUE : 0.4Nm(3.6LB.IN)  
STRIP LENGTH : 7-8mm

PRODUCT NUMBER CODE:

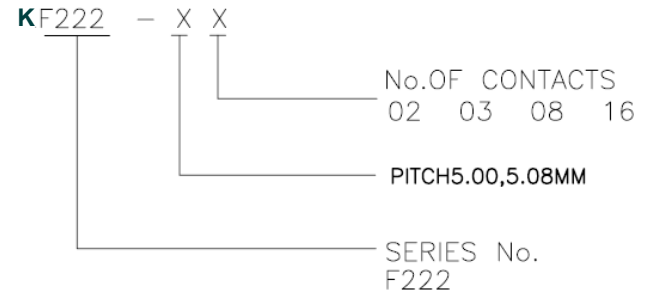

Disponibili con passo : 7.5, 7.62MM

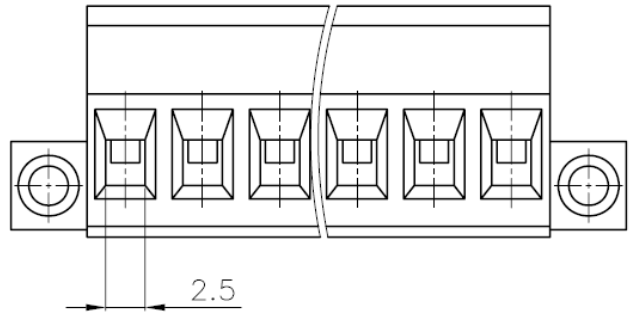
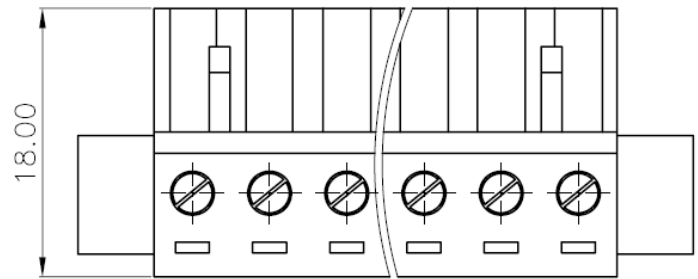

GENERAL TOLERANCE		ANGLE TOLERANCE		PROJECTION		TITLE	PLUG GABLE TERMINAL BLOCKS
X.	±0.60	X.	±5°	UNITS	mm		PITCH5.00,5.08MM
.X	±0.38	.X	±3°	SHEET SIZE	A4	SERIES	KF222 SERIES
.XX	±0.25	.XX	±2°	 <a href="http://www.toptek-co.com">www.toptek-co.com</a>			
DRAWING TYPE		CUSTOMER					
SCALE	1:1	SHEET	1 OF 1				
DRAWING NO.		F222-XXXX					